



City of El Cajon
Building and Fire Safety Division
200 Civic Center Way
El Cajon, CA 92020
Phone: (619) 441-1726

Deck Detail

Inspection request line: (619) 441-6210

When is a permit required for my residential deck?

When the decks 200 sq. ft. or more in area, or more than 30 inches above grade at any point, or attached to the dwelling and serving as part of the exit path.

Are there any setbacks for my deck?

A deck is required to maintain a five foot setback from all property lines.

How do I obtain a permit for my deck?

Step 1 - Draw a plot plan showing the dimensions of the property, all structures on the property, the proposed deck and distances to property lines (an example of a plot plan is available on the City of El Cajon website).

Step 2 - Use this residential deck detail to determine the size of joist, girders, and footings for your deck structure.

Step 3 - Submit three copies of your plot plan along with this detail to the El Cajon Building and Fire Safety Division. The permit technician will help you through the rest of the permit process.

What inspections do I need?

You will need to call for three different inspections to complete your residential deck, (1) A footing inspection before concrete is placed, (2) a ledger inspection before the ledger is covered, and (3) a final inspection when the work is complete. The inspection card and permit must be kept on site for the inspector to sign.

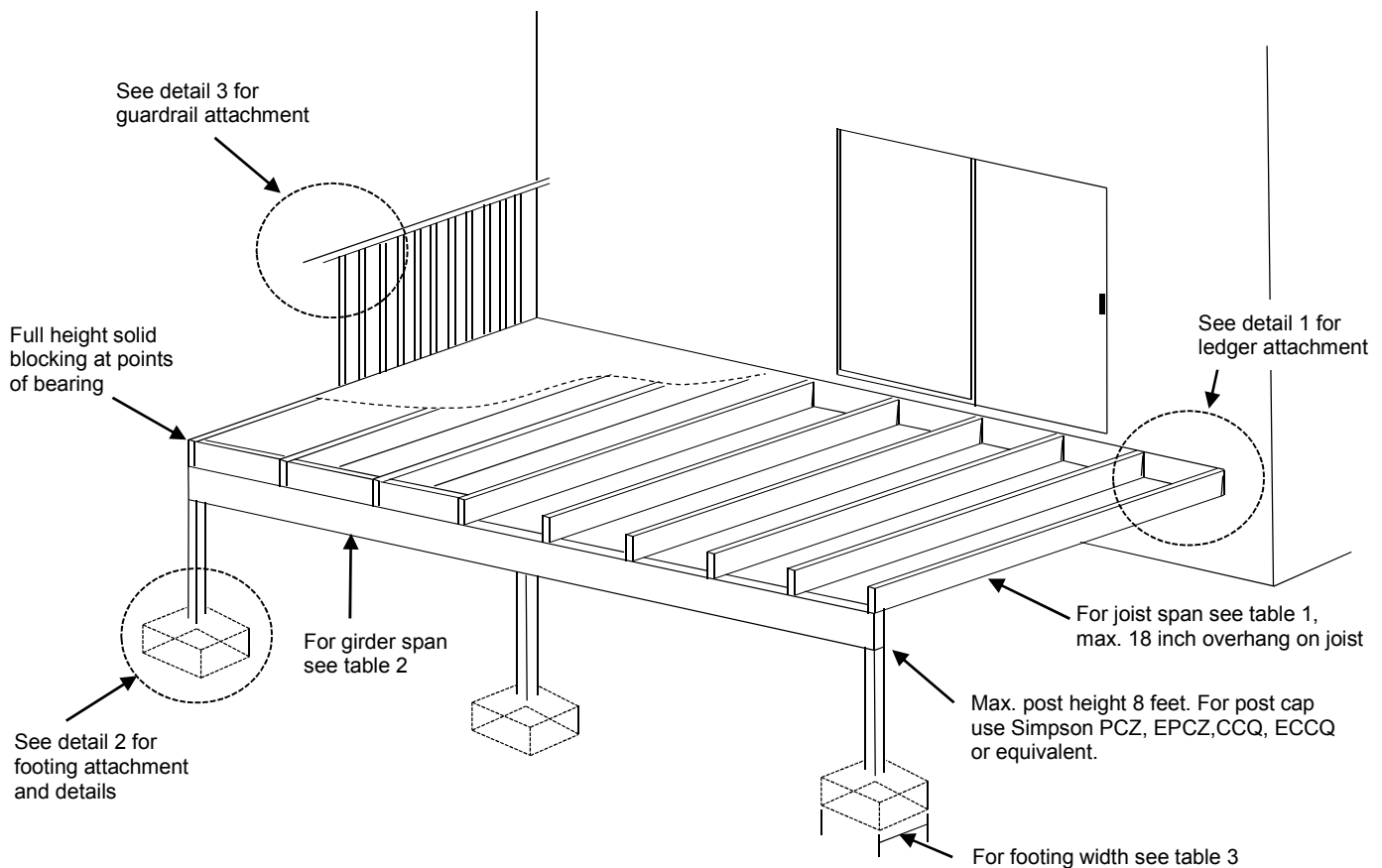

Table 1 – Minimum Joist Size (cantilever allowed up to the depth of the joist)

Size (inches)	Spacing (inches)	Allowable Span (feet and inches)	
		DF/L #2	Redwood
2x6	12	9'-6"	8'-10"
	16	8'-8"	8'-0"
	24	7'-2"	7'-0"
2x8	12	12'-6"	11'-8"
	16	11'-1"	10'-7"
	24	9'-1"	8'-8"
2x10	12	15'-8"	14'-11"
	16	13'-7"	13'-0"
	24	11'-1"	10'-7"
2x12	12	18'-0"	17'-5"
	16	15'-9"	15'-1"
	24	12'-10"	12'-4"

- If joists are within 18 inches of grade use pressure treated Douglas Fir/larch or foundation grade redwood.

Table 2 – Minimum Girder Size

Post Spacing	Joist Span in feet				
	6'	8'	10'	12'	14'
4'	4x4	4x4	4x4	4x4	4x6
6'	4x6	4x6	4x6	4x6	4x8
8'	4x6	4x8	4x8	4x10	4x10
10'	4x8	4x10	4x10	4x12	4x12
12'	4x10	4x12	4x12	4x14	4x14
14'	4x12	4x14	4x16	4x16	

Table 3 – Minimum Footing Width in Inches

Post Spacing	Joist Span in feet				
	6'	8'	10'	12'	14'
4'	12	12	12	12	14
6'	12	14	14	16	16
8'	14	16	16	18	20
10'	16	18	18	20	22
12'	18	18	20	22	24
14'	18	20	22	24	24

- Assume 1,500 psf soil bearing capacity and 2500 psi Concrete.
- Minimum depth for all footings is 12 inches into Natural grade.

Detail 1 – Ledger Attachment

See section R507.2. Up to 10 foot joist span use 5x1/2 lag screw at 16 inches on center. Over 10 foot to 14 foot use 5x1/2 lag screw at 12 inches on center. Stagger lag screws.

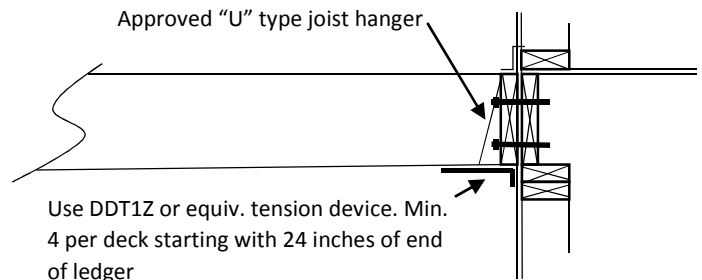

Ledger min. size equal to size of joist. Lags/bolts hot dipped or galvanized.

Detail 2 – Footing and Attachment Detail (for footing width see table 3)

Use Simpson ABU44, PBS44, CBS44, EPB44 or equivalent standoff base

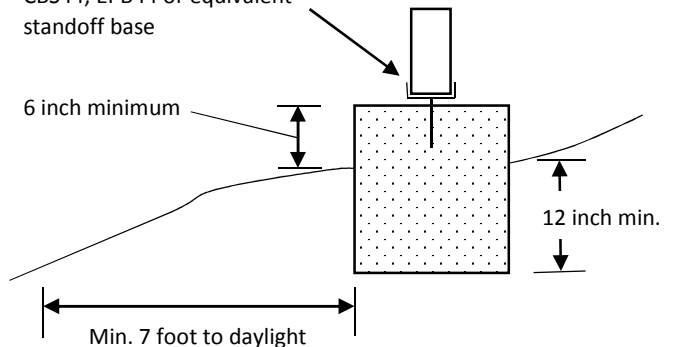

Detail 3 – Guardrail Attachment

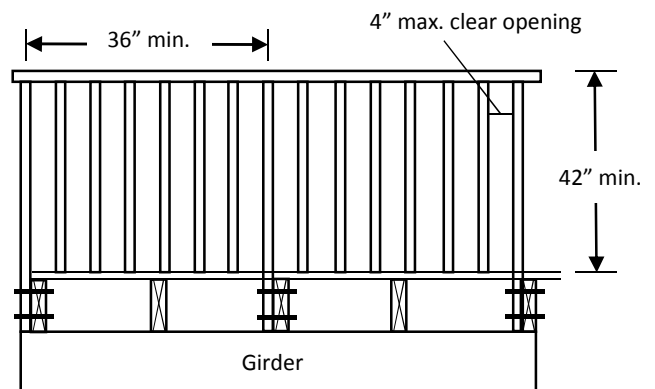

Use 2-1/2 diameter through bolts. Bolts must be positioned 1-1/2" from edge of member.